



2.4GHz GaAs RF Front-End Module with PA, LNA and Switch

Description

BHWM257 is a Transmit/Receive RF Front-End Module in advanced GaAs E/D-PHEMT process that integrates a power amplifier, a low noise amplifier and two SPDT switches. With ultra-low noise figure (1.7dB) and power consumption (22mA for +13dBm at antenna), BHWM257 features the industry's leading performance for 2.4GHz applications including Bluetooth/BLE, ZigBee/CSA, Thread/Matter and other IoT connectivity devices. BHWM257 has on-chip matching at all RF ports and ESD protection at all I/O ports. It is housed in a simple, compact 2x2mm 8-L DFN (Dual Flat No-Lead) package.

Key Features

- Advanced GaAs E/D PHEMT Process
- Tx Power: 13dBm/3.3V, 15dBm/4.2V
- Tx Total Current: 22mA/13dBm, 30mA/15dBm
- Tx Gain: 13dB
- Rx Gain/Noise Figure: 13dB/1.7dB at 3.3V
- LNA High-Linearity: Input P1dB~-2dBm at 3.3V
- LNA Current: 4~15mA Adjustable
- Robust ESD: ±700V HBM; ±2kV CDM
- Compact 2x2mm DFN-8L Package

Key Applications

- ZigBee/Thread/Matter Range Boosters
- 2.4GHz IoT Modules
- Remote Control
- Asset Tracking
- Smart Home, Smart Meters
- Wireless Audio/Video/Microphone
- Generic 2.4GHz TDD Radio Designs

Functional Block and Package Information

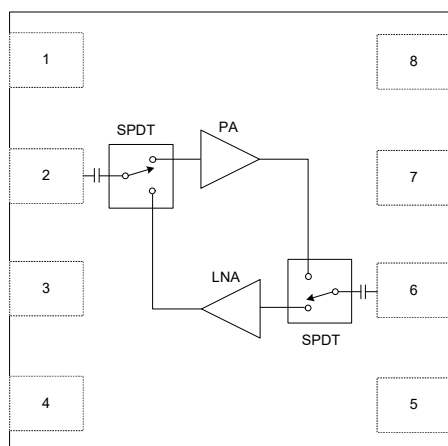

2x2x0.75mm 8L DFN



2.4GHz GaAs RF Front-End Module with PA, LNA and Switch

Pin Assignment and Pin Description

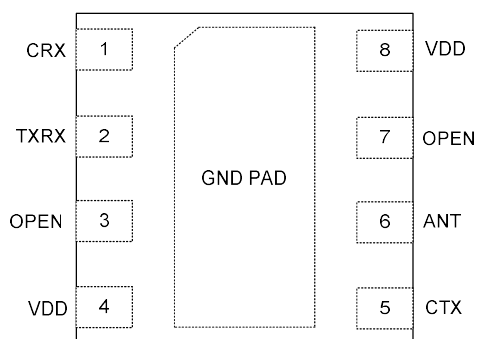

(Top "See-Through" View)

Pin #	Pin Name	Description
1	CRX	Control Voltage for Receive Mode
2	TXRX	RF Port for PA Input and LNA Output
3	OPEN	Must be kept OPEN
4	VDD	DC Power Supply
5	CTX	Control Voltage for Transmit Mode
6	ANT	Antenna Port
7	OPEN	Must be kept OPEN
8	VDD	DC Power Supply

Absolute Maximum Ratings

Parameter	Rating	Unit
Maximum Supply Voltage	4.5	V
Maximum Control Voltage	3.6	V
Maximum Supply Current	50	mA
Maximum Input Power to PA	+10	dBm
Maximum Input Power to LNA	+10	dBm
Operation Temperature	-40 to +85	°C
Storage Temperature	-40 to +150	°C
Moisture Sensitivity Level	MSL1	

Note: Do not exceed any single or combination of the above parameters. Sustained operation at or above the Absolute Maximum Ratings may result in permanent damage to the device. Maximum Input Power Rating assumes 50-Ohm load impedance.



2.4GHz GaAs RF Front-End Module with PA, LNA and Switch

Electrical Specifications: Transmit Mode

Parameter	Condition	Specification			Unit
		Min.	Typ.	Max.	
Operating Frequency		2.4		2.5	GHz
Operating Voltage		1.2	3.3	4.2	V
Logic Control Voltage	For CTX=High	1.2	3.3	3.6	V
Quiescent Current*	VDD=CTX=3.3V, CRX=0		8		mA
Shutdown Current	VDD=3.3V, CTX=CRX=0		0.5		uA
Small-Signal Gain	Pin=-30dBm		13		dB
Output Power 1 (GFSK)	VDD=3.3V, Pin=3dBm		13		dBm
Output Power 2 (GFSK)	VDD=4.2V, Pin=3dBm		15		dBm
Output Power 3 (16QAM)	HDT8/7.5Mbps, EVM=-22dB		10		dBm
Total Current	VDD=3.3V, Pout=13dBm		22		mA
Harmonics	2 nd ~ 6 th , with Pi-Filter on EVB		-44	-42	dBm/MHz
Input Return Loss	2.4-2.5GHz		10		dB
Output Return Loss	2.4-2.5GHz		8		dB
Tx Noise Figure	2.4-2.5GHz		2		dB
Isolation	2.4-2.5GHz		25		dB
Ramp-On Time	10% to 90%		100		ns
Stability (Load VSWR)	Pin=+5dBm (PA Saturated)		10:1		

*Quiescent current can be reduced by using lower CTX control voltage, or with an external serial resistor on CTX line.

Electrical Specifications: Receive Mode

Parameter	Condition	Specification			Unit
		Min.	Typ.	Max.	
Operating Frequency		2.4		2.5	GHz
Operating Voltage		1.2	3.3	4.2	V
Logic Control Voltage	For CRX=High	1.2	3.3	3.6	V
Quiescent Current*	VDD=CRX=3.3V, CTX=0		8		mA
Shutdown Current	VDD=3.3V, CTX=CRX=0		0.5		uA
Small-Signal Gain	Pin=-30dBm		13		dB
Rx Noise Figure	VDD=CRX=3.3V, CTX=0		1.7		dB
Input P1dB			-2		dBm
IIP3			+6		dBm
Input Return Loss			11		dB
Output Return Loss			10		dB
Isolation			25		dB
Ramp-On Time	10% to 90%		100		ns
Stability (Mu Factor)		1			

* Quiescent current can be reduced by using lower CRX control voltage, or with an external serial resistor on CRX line.



2.4GHz GaAs RF Front-End Module with PA, LNA and Switch

Logic Control

CRX (Pin 1)	CTX (Pin 5)	Mode of Operation
0	1	Transmit (PA On)
1	0	Receive (LNA On)
0	0	Shutdown (10dB IL)
1	1	Not Allowed

Application Schematic

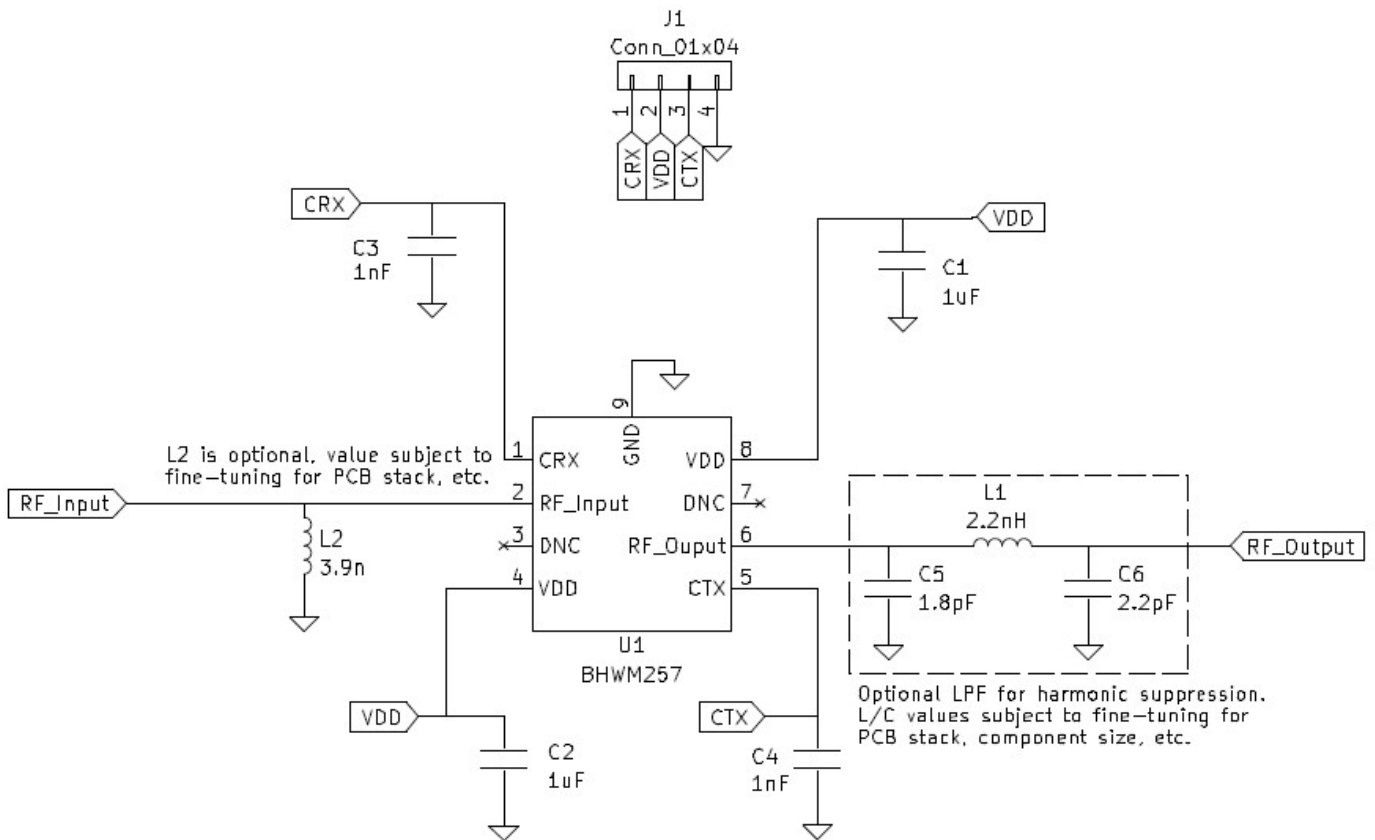



2.4GHz GaAs RF Front-End Module with PA, LNA and Switch

Evaluation Board

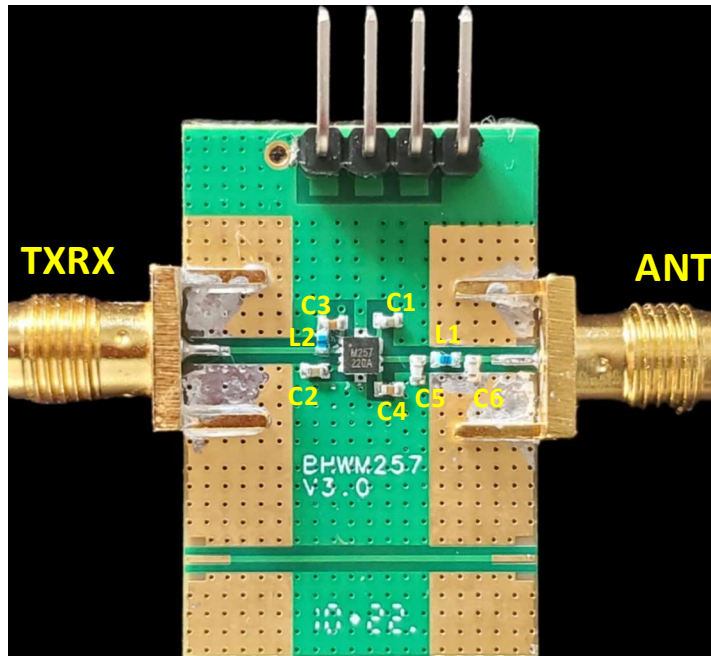

RF Characteristics

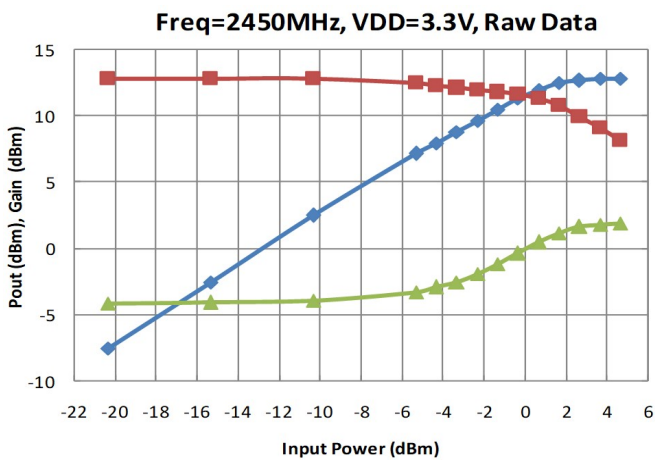

—◆— Pout (dBm) —■— Gain (dB) —▲— Current (mA)

Typical Tx Power Sweep Data at VDD=3.3V

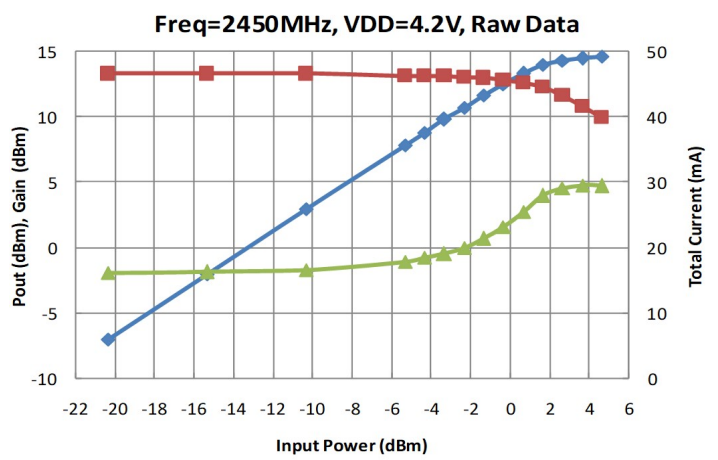

—◆— Pout (dBm) —■— Gain (dB) —▲— Current (mA)

Typical Tx Power Sweep Data at VDD=4.2V



2.4GHz GaAs RF Front-End Module with PA, LNA and Switch

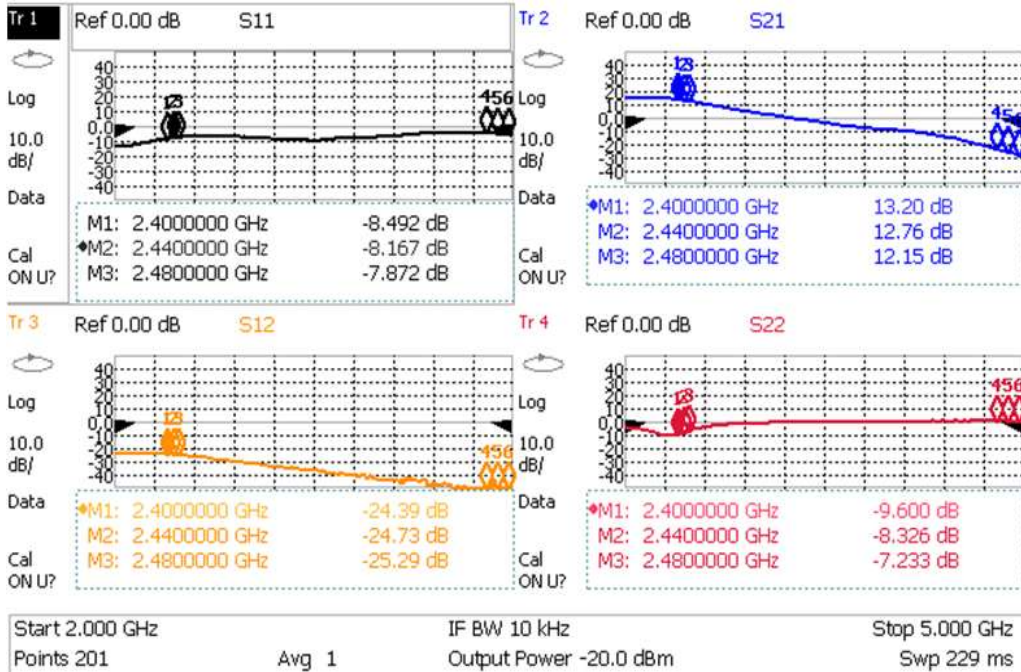

Typical S-Parameters in Tx Mode, VDD=CTX=3.3V, CRX=0

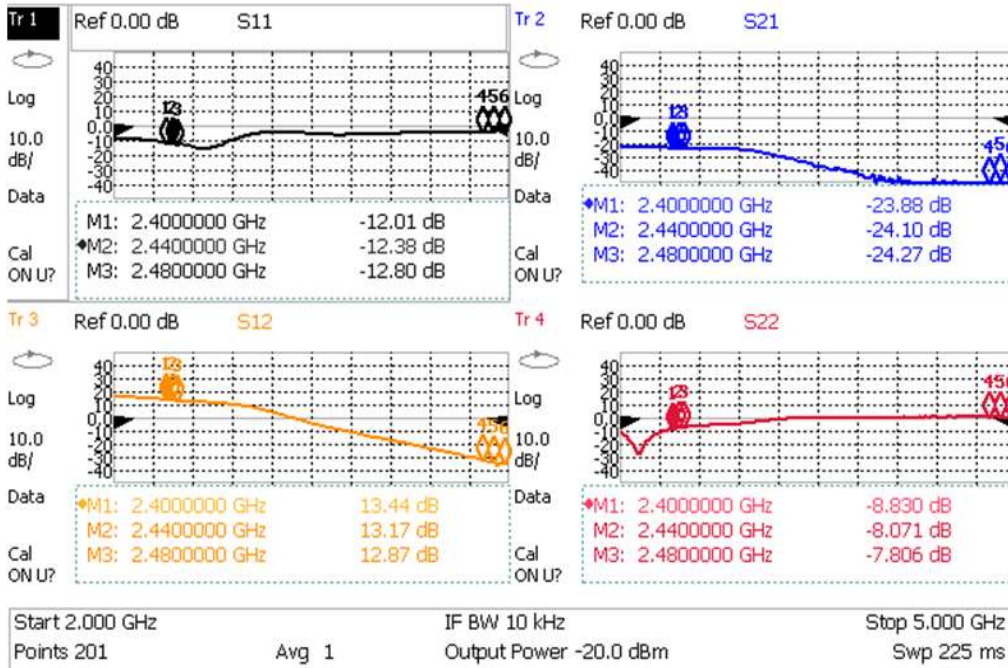

Typical S-Parameters in Rx Mode, VDD=CRX=3.3V, CTX=0



2.4GHz GaAs RF Front-End with PA, LNA and Switch

Package Drawing and Dimensions

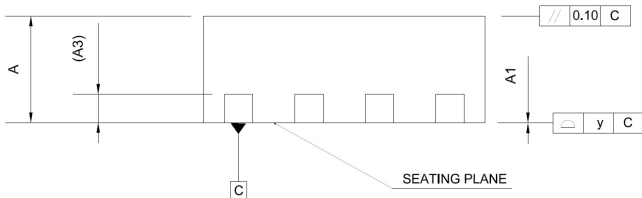
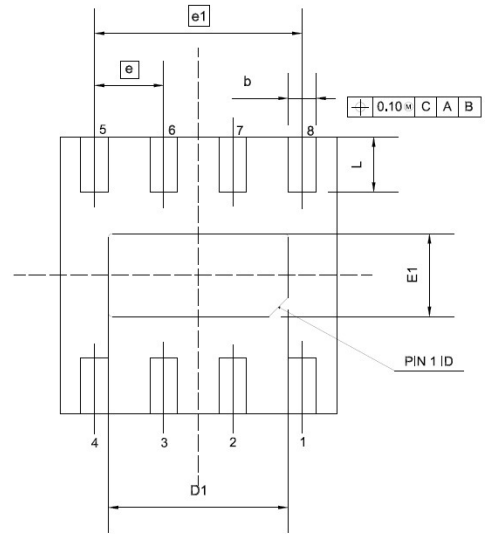
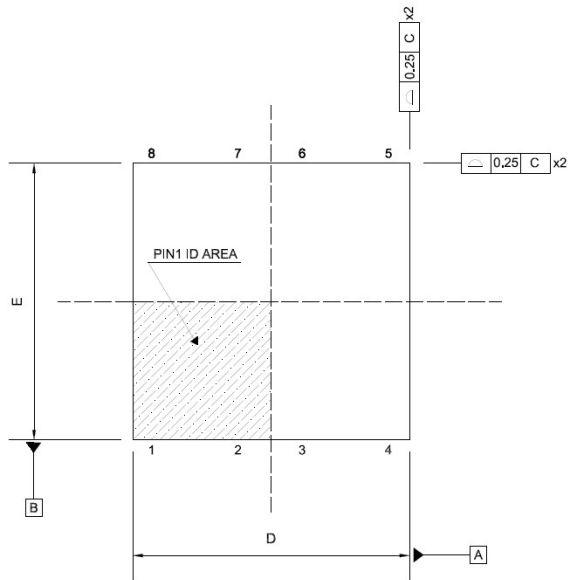

SYMBOL	DIMENSION (MM)			DIMENSION (MIL)		
	MIN	NOM	MAX	MIN	NOM	MAX
A	0.70	0.75	0.80	27.6	29.5	31.5
A1	0.00	0.02	0.05	0	0.8	2
A3	0.02 REF			8 REF		
b	0.15	0.20	0.25	6	8	10
D	2.00 BSC			79 BSC		
D1	1.25	1.30	1.35	49.2	51.2	53.2
E	2.00 BSC			79 BSC		
E1	0.55	0.60	0.65	21.6	23.6	25.6
e	0.50 BSC			19.7 BSC		
e1	1.50 BSC			59 BSC		
L	0.30	0.40	0.50	11.8	15.7	19.7
y			0.08			3



2.4GHz GaAs RF Front-End Module with PA, LNA and Switch

Recommended Reflow Soldering Profile

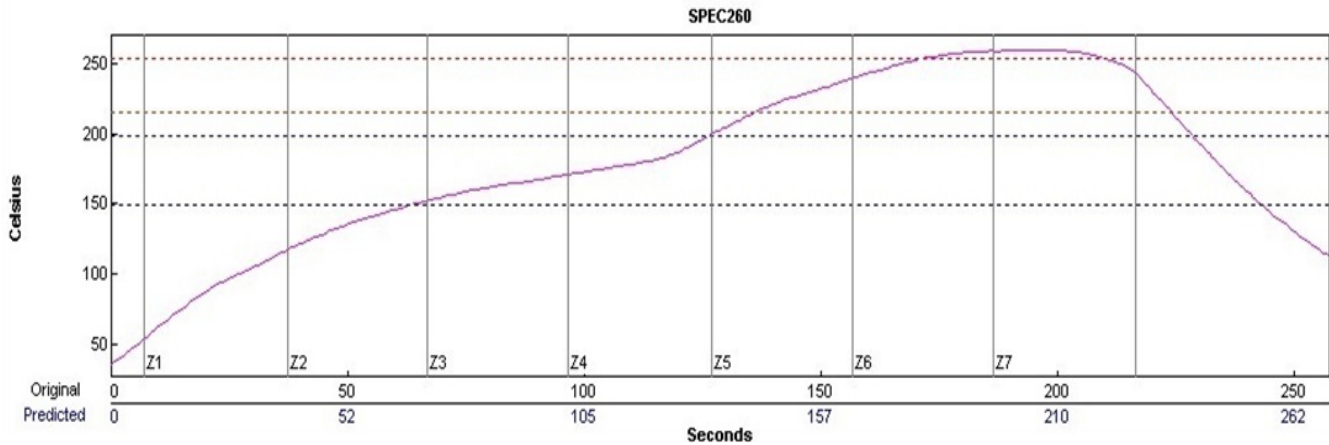

Package Marking



- ← Line 1: Pin 1 Indicator
- ← Line 2: Part Number, M257
- ← Line 3: Datecode, YWWA

Date Code Description

Y: Year Code (e.g., 1 for 2021)

WW: Working Week (01~52)

A: Revision Code (Default=A)